

A+P Art. No.: 80.0047.5521

Detail A Scale 2:1

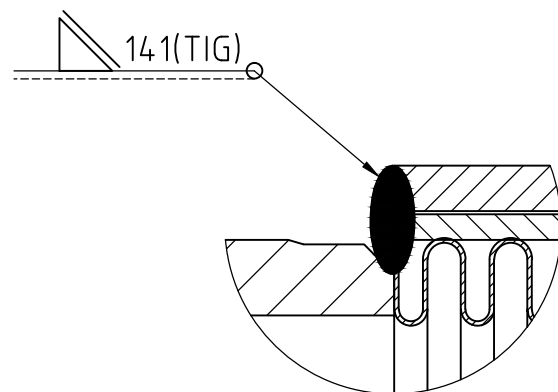

3	2	Tube ø22 x 40	1.4305	
2	2	End sleeve DN16	1.4301	
1	1	ASSIWELL® 066 Hose DN16 x 400	1.4404	

Item	Quantity	Description	Material	Remarks
Origin		Established	21.01.2014	S.Xu XUSU Scale 2:1
Substitute of		Approved	07.03.2014	Baroni Loredana BAL
Replaced by		Amendment	a 07.03.2014	S.Xu XUSU
Separate part list				

Measurements without tolerance: DIN EN ISO 13920-BF	For this document and the therein represented items we reserve all rights. Without our explicit consent the reproduction, the disclosure to third party or the utilisation of its content is prohibited. © Copyright by Angst + Pfister 2014		<b>ASSIWELL® 066 Hose DN16</b>		Division FT
	 www.angst-pfister.com		<b>APIT 3.109 995.00 a</b>		Format A3
					Number of sheets 1 Sheet 1 CAD